



PREMIER - 1



- Chassis:** Two half-frames with central articulated joint for steering and ground gearing oscillation. Heavy duty type.
- Engine:** Lombardini make. Four stroke diesel, four cylinders, forced water cooling. Maximum power 47 CV to 3.000 r.p.m.
- Transmission:** Hydrostatic type, with electrical selection of two speed forwards and backwards. Shutting inching pedal.
- Axles:** Both rigid. Loading capacity 2.500 kg each. All wheel drive
- Steering:** Hydraulic steering. Fluid drive acting on the central articulated joint through oleodynamic cylinder. 35° each side.
- Brakes:**
 - Service: Hydraulic external disc acting on four wheels.
 - Parking: Disc type on transmission with hand lever control.
- Driving Seat:** Gyrotory driving seat for transferring position.
- Hydraulic circuits:** Three different circuits with only one tank:
 - TRANSMISSION: Hydrostatic circuit cooling through oil-air intercooler.
 - DRUM ROTATION: Hydrostatic circuit.
 - WHOLE WORKING: Gear pump circuit.
- Drum:** Concrete output capacity.....1m³
Double mixing spiral blades.
Inclinable drum to facilitate the dry mixtures unloading.
Manual speed regulation.
- Loading:** Push type front loading bucket for volumetric dosage.
200 L Capacity.

MADRID: Ctra de Valencia, Km 19,200. 28529 RIVAS VACIAMADRID (MADRID). FAX:916701005. e-mail:madrid@mlorenzana.com

LEÓN: Pol. Ind. Villacedré. 24194 VILLACEDRÉ (LEÓN). FAX:987849036. e-mail:leon@mlorenzana.com

VALENCIA: Pol. Ind. El Oliveral C/C, 12. 46190 RIBARROJA DEL TURIA (VALENCIA). FAX:961643073. e-mail:valencia@mlorenzana.com

PREMIER - 1

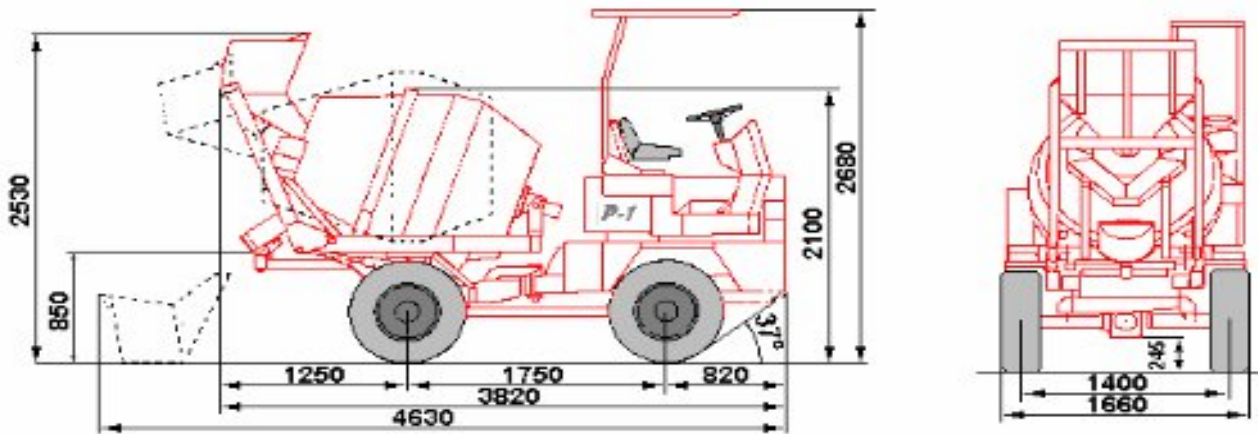

Water System:

Hydraulic operated self-priming water pump. The water is supplied from an external source, taken directly to the drum, to the tank or the washing hose. It can also transferred from the own tank to the drum or the washing hose. Litre counter.

Unloading:

By reversing the rotation of the drum through a vertical and horizontal adjustable pouring chute. Two removable pouring chutes when necessary for pouring at distance.

Cycle:

Load and mix 7/10 min.

Seep:

1st 0 – 9.5 km/h
2nd 0 – 20 km/h

Max. Slope:

Fully loaded: 30%

Steering Radius:

Internal 1.94 m
External 3.65 m

Electrical Equipment:

12 V battery and all regular lighting devices and signals for road traffic.

Capacities:

-Water tank: 200 L
-Oil tank: 70 L
-Fuel tank: 45 L

Tyres:

10.0 / 75 – 15

Weight:

2.650 kg

MADRID: Ctra de Valencia, Km 19,200. 28529 RIVAS VACIAMADRID (MADRID). FAX:916701005. e-mail:madrid@mlorenzana.com

LEÓN: Pol. Ind. Villacedré. 24194 VILLACEDRÉ (LEÓN). FAX:987849036. e-mail:leon@mlorenzana.com

VALENCIA: Pol. Ind. El Oliveral C/C, 12. 46190 RIBARROJA DEL TURIA (VALENCIA). FAX:961643073. e-mail:valencia@mlorenzana.com

www.mlorenzana.com TEL. 902 151 236