



PREMIER - 4



- Chassis:** Monoblock. Heavy duty type
- Engine:** Ecological, Perkins make. Model 1104D 44T. Four stroke diesel, four cylinders, forced liquid cooling. Power DIN 74.5 kw to 2400 r.p.m.
- Transmission:** Hydrostatic type. Axial-pistons pump of variable displacement. Hydraulic motor with axial pistons of variable displacement. Both with automatic regulation through DA valve. Two speeds gear box in both driving directions.
- Axles:** Steering type front and rear axle , with rear with oscilating assembly. Loading capacity 8000 kg each. AWD.
- Steering:** Hydraulic steering operating either on one axle or on both.
- Brakes:**
- Service: Hydraulic internal disc type in oil bath acting on four wheels.
 - Parking: Disc type on transmission with hand level control.
- Reserved braking when engine stops.
- Cabin:** Front closed cabin with windscreen wipers and regulable seat.
- Hydraulic Circuits:**
- Four different circuits with only one tank:
- TRANSMISSION: Hydrostatic circuit cooling through oil-air intercooler
 - DRUM ROTATION: Hydrostatic circuit
 - PUMP OPERATED STEARING AND BREAKING
 - PUMP OPERATED SERVICE.

MADRID: Ctra de Valencia, Km 19,200. 28529 RIVAS VACIAMADRID (MADRID). FAX:916701005. e-mail:madrid@mlorenzana.com

LEÓN: Pol. Ind. Villacedré. 24194 VILLACEDRÉ (LEÓN). FAX:987849036. e-mail:leon@mlorenzana.com

VALENCIA: Pol. Ind. El Oliveral C/C, 12. 46190 RIBARROJA DEL TURIA (VALENCIA). FAX:961643073. e-mail:valencia@mlorenzana.com



PREMIER - 4

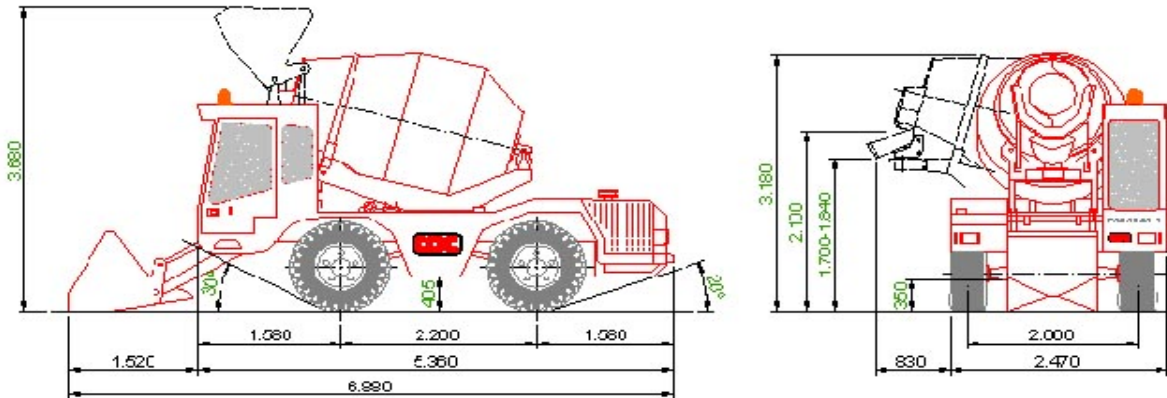

- Drum:** Turn on 270° to be able to unload at any point around the machine. Double mixing spiral blade. Inclined drum to facilitate the dry mixture's unloading.
 Concrete output capacity.....3 m³
 Direct unloading height.....2.10 m
 Unloading height by chutes.....1.80 m
 Hydraulic rotating drum for loading-mixing and unloading, with electrical speed regulation.
- Loading:** Push type front loading bucket for volumetric dosage with hydraulic unloading door. 550 L capacity
- Water System:** Hydraulic operated self-priming water pump. The water is supplied from an external source, taken directly to the drum, to the tank or the washing hose. It can also be taken from the own tank to the drum or the washing hose. Litre counter
- Unloading:** By reversing the rotation of the drum and through vertical and horizontal adjustable pouring chute. Two removable pouring chutes if necessary when pouring at distance.
- Cycle:** Load and mix 7/10 min
- Speed:** 1st0 – 8 km/h
 2nd0 – 20 km/h
- Max. Slope:** Fully loaded: 30%
- Steering Radius:** Internal.....1.20 m
 External.....4.33 m
- Electrical Equipment:** 12 V battery with regular lighting devices and signals for road traffic.
- Capacities:** Water tank.....800 L
 Oil tank.....125 L
 Fuel tank.....105 L
- Tyres:** 16 / 70 - 20
- Weight:** 6.500 Kg