



GENERAL SPECIFICATIONS

- CHASSIS:** Monoblock. Heavy duty type.
- ENGINE:** Deutz diesel TCD 2012 L042V (TIER III-COM III), 4 cylinders, turbo intercooler. Forced water cooling. Power DIN 140 HP to 2.400 r.p.m. It is designed to work at 4700 MASL.
- TRANSMISSION:** Hydrostatic type. Axial pistons pump of variable displacement. Hydraulic motor at axial pistons. Both with automatic regulation through Da-valve. Two speed gearbox in both directions.
- AXLES:** Steering type front axle with oscillating assembly. Fixed rear axle. Loading capacity 8000 kg each AWD.
- STEERING:** Hydraulic steering on front axle.
- BRAKES:**
 -Service: Hydraulic internal disc type in oil bath acting on four wheels.
 -Parking: Disc type on transmission with hand lever control.
- DRIVING SEAT:** Giratory driving seat on 180° for both driving directions.
- HIDRAULIC CIRCUITS:** Four different circuits with only one tank:
 - TRANSMISSION: Hydrostatic circuit air cooling.
 - DRUM ROTATION: Hydrostatic circuit air cooling.
 - STEERING: Gear pump circuit.
 - BRAKE: Gear pump circuit.
- DRUM:**
 Concrete output capacity:.....4m³
 Direct unloading height:.....1465mm
 Unloading height by chutes:.....1100mm
 Hydraulic rotating drum for loading-mixing and unloading.
 Electrical speed regulation.

All data are subset to modifications without prior notice

MADRID: Ctra de Valencia, Km 19,200. 28529 RIVAS VACIAMADRID (MADRID). FAX:916701005. e-mail:madrid@mlorenzana.com

LEÓN: Pol. Ind. Villacedré. 24194 VILLACEDRÉ (LEÓN). FAX:987849036. e-mail:leon@mlorenzana.com

VALENCIA: Pol. Ind. El Oliveral C/C, 12. 46190 RIBARROJA DEL TURIA (VALENCIA). FAX:961643073. e-mail:valencia@mlorenzana.com

www.mlorenzana.com TEL. 902 151 236

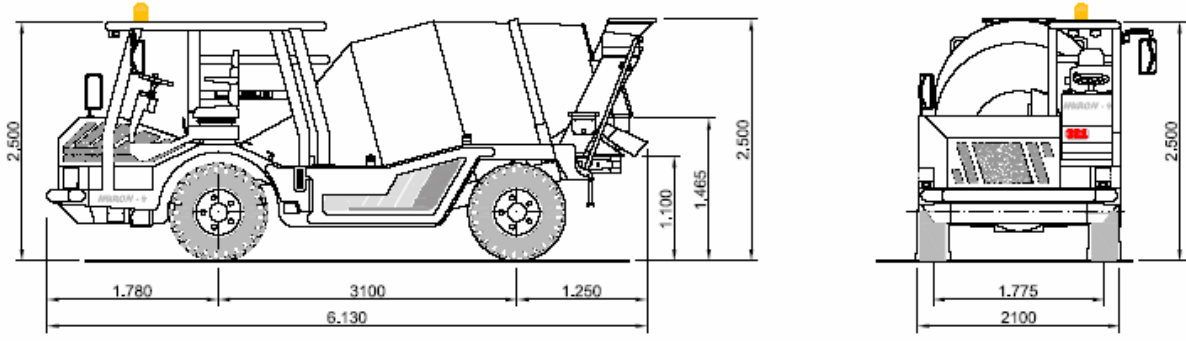

WATER SYSTEM:

Hydraulic operated self-priming water pump.
The water is supplied from an external source, taken directly to the drum, to the tank or the washing hose. It can also be taken from the truck mixer tank to the drum or the washing hose.
Litre counter.

UNLOADING:

By reversing the rotation of the drum and through vertical and horizontal adjustable pouring chute.
One removable pouring chute if necessary when pouring at distance.

SPEED:

1st0 - 8 Km/h
2nd0 - 20 Km/h

MAX. SLOPE:

Fully loaded: 30%

STEERING RADIUS:

Internal:.....4.150 mm
External:.....7.800 mm

ELECTRICAL EQUIPMENT:

12 V battery and all regular lighting devices and signals for road traffic.

CAPACITIES:

- Water tank:.....420l
- Oil tank:.....200l
- Fuel tank:.....110l

TYRES:

MICHELÍN XZHR2 10'00R20 16PR

WEIGHT:

5.7 T

All data are subset to modifications without prior notice

MADRID: Ctra de Valencia, Km 19,200. 28529 RIVAS VACIAMADRID (MADRID). FAX:916701005. e-mail:madrid@mlorenzana.com

LEÓN: Pol. Ind. Villacedré. 24194 VILLACEDRÉ (LEÓN). FAX:987849036. e-mail:leon@mlorenzana.com

VALENCIA: Pol. Ind. El Oliveral C/C, 12. 46190 RIBARROJA DEL TURIA (VALENCIA). FAX:961643073. e-mail:valencia@mlorenzana.com

www.mlorenzana.com TEL. 902 151 236